



SEAT-DT5532



MADE IN THE
★USA★
WITH PRIDE



NOTE: SEAT CUSHIONS ARE SOLD SEPARATELY AND NOT INCLUDED IN THIS KIT.

Installation Instructions For Yamaha Drive 2

TABLE OF CONTENTS:

- Tools required for Assembly
- Contents of this Kit
- Step 1 – Prepare Car for Installation
- Step 2 – Seat Back Support Installation
- Step 3 – Armrest Installation
- Step 4 – Bumper Angle & Bracket Installation
- Step 5 – Rear Seat Mounting
- Step 6 – Cushion Installation
- Step 7 – Footrest Installation
- Step 8 – Safety Bar Installation

Optional Accessories

Sold Separately



BAG WELL COVER



BAG HOLDER STRAPS



SAFETY BAR HANDLE / BAG SUPPORT / CHAIR HOLDER



STORAGE BIN



SOFT CARGO CARRIER



HEAVY-DUTY LEAF SPRINGS
(Recommended)



CAUTION! SEAT BASE LID

Do not open the seat base lid past 90° before the seat base & seat back cushion have been installed on the car

To prevent potential damage to the seat base lid hinges, install the optional Storage Bin **ONLY AFTER** the rear seat and seat back cushion have been installed on the car.

Tools required for Assembly

- ✓ Phillips head screwdriver.
- ✓ Socket & open-end wrench.
- ✓ Cordless drill with adjustable clutch (optional).
- ✓ Rubber mallet (optional).

*** WARNING ***

DO NOT use an impact driver for tightening the fasteners in this assembly. Over tightening can damage and/or create physical stresses that will void the manufacturers warranty. Hand tight or #5 setting on a drill clutch is recommended.

Caution:

Please read through the instructions carefully before beginning installation. Installer is responsible for damage if instructions are not followed properly. Look behind each drill or cut location **BEFORE YOU DRILL OR CUT**. Installer is responsible for damage (i.e. drilling/cutting into a wiring harness, battery, fuel tank etc.). Extra installers will be helpful in some parts of the installation. Refer to vehicle's maintenance manual for torquing specifications on reused hardware. **IMPORTANT:** Do not fully tighten hardware until instructed.

Contents of this kit:

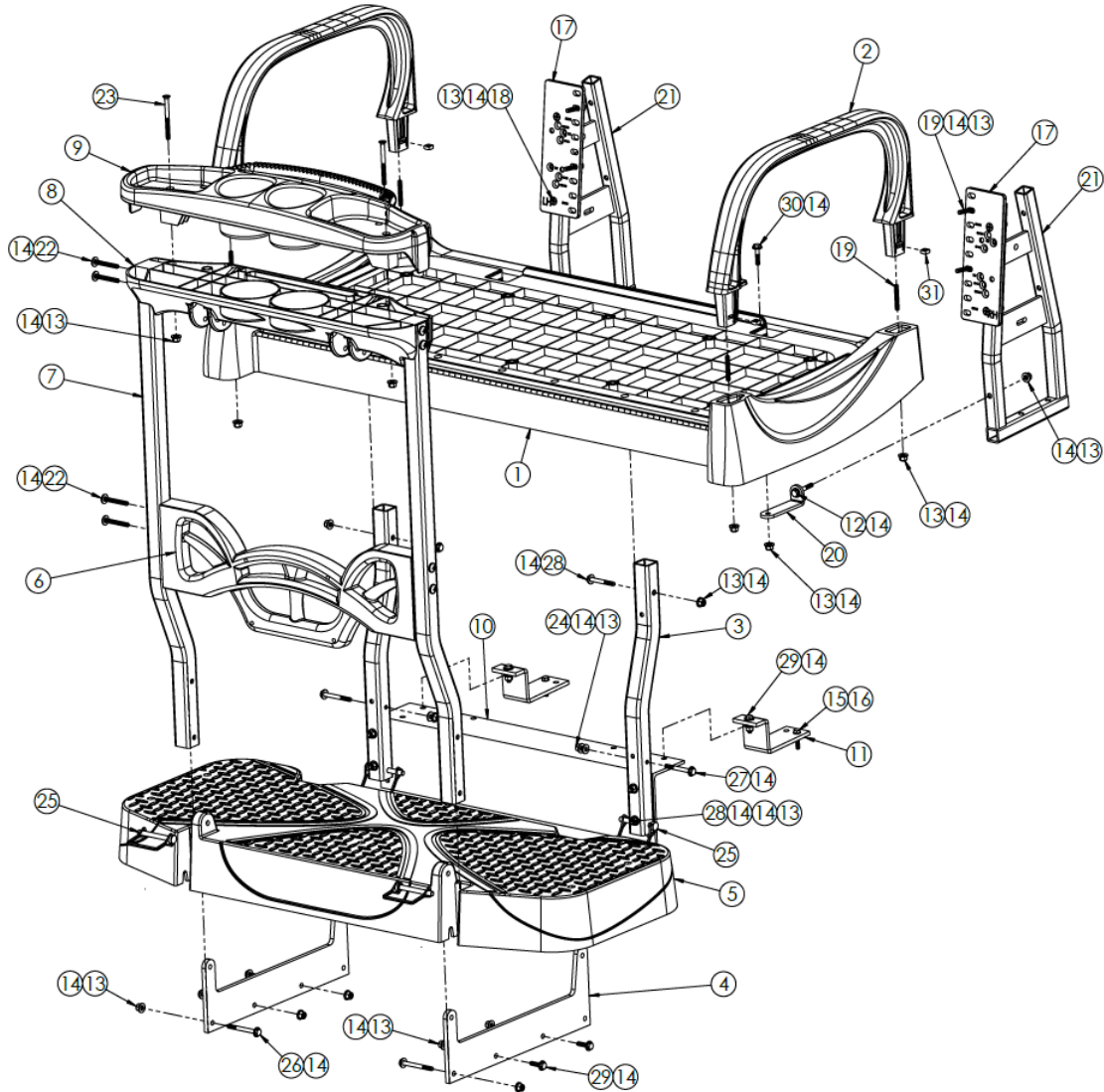

Item #	Part Number	Qty.
1	SEAT-DT5500-SB	1
2	MX5 ARM REST	2
3	SEAT-BL5512	2
4	F/R SUPP BAR	2
5	SEAT-DT5500-FP	1
6	SEAT-DT5500-CB	1
7	SEAT-SB5504	2
8	SEAT-SB5503	1
9	SEAT-SB5502	1
10	SEAT-BA5532	1
11	SEAT-BA5532-T	2
12	.25 x 1.75 SS H	2
13	.25 NYLOC	42
14	.25 WASHER SS	70
15	M6-1.0 X 30 SS	2
16	M6 FW SS	2

Item #	Part Number	Qty.
17	UNIV SPLATE-1	2
18	.25 X 1.75 FHPS	4
19	.25X1.75 FTSTUD	8
20	MX5 DV17 RSK BKT	2
21	SBS DV17 ASSY	2
22	.25 x 2.0 THPSS	8
23	.25 x 3.0 FHPS	2
24	SPACER .285 x .75	2
25	MX5 D RING PIN	4
26	.25 X 2.50 HEXS	2
27	.25 X 2.25 HEXS	2
28	.25 X 2.0HEXSS	6
29	.25 X 1.0 HEXSS	6
30	.25 X 1.25 HEXS	2
31	.25 SQ. NUT SS	4

Contents of this kit: (Continued)
Scale Hardware Guide 1:1

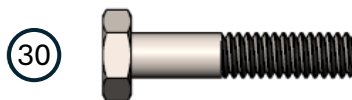
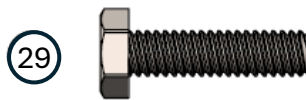
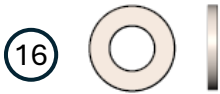
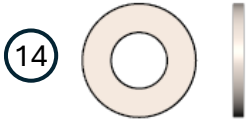

STEP (1) PREPARE CAR FOR INSTALLATION

Remove the following items to prepare the car for Rear Seat Kit Installation:

- Top
- Rear Top Supports / Drain Tubes
- Rear Basket / Bag Rack Assembly
- Bench Back Cushion
- Factory Seat Back Supports.

NOTE: Save and separate factory hardware for later use.



STEP (2) SEAT BACK SUPPORTS INSTALLATION

Install the supplied seat back supports as shown using the factory hardware saved from the previous step. Once they have been tightened down, remove the double-sided tape backing on the supplied hole covers to put in place of the rubber grommets taken off in the previous step.

NOTE: Fully tighten bolts.

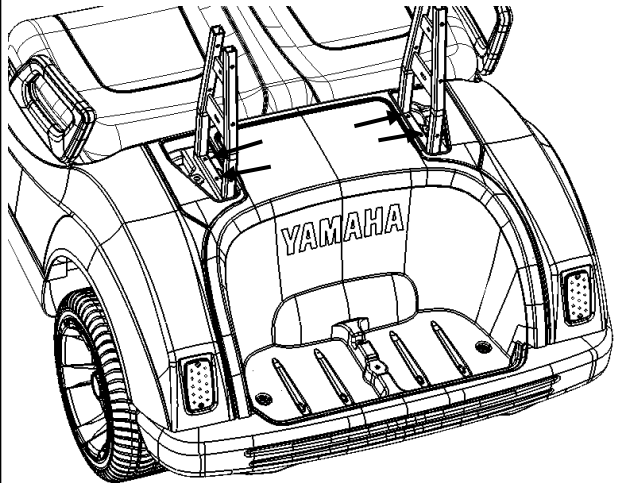
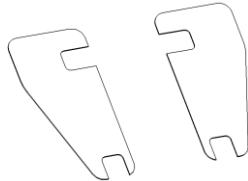

STEP (3.1) ARMREST INSTALLATION

Prepare the armrests by inserting **1/4" square nuts** into the slots on both ends of each armrest and thread a **1/4" x 1.75" long stud** through the nut until it stops.

Fasteners located in Pack #1 of SEAT-DT5500-HW.

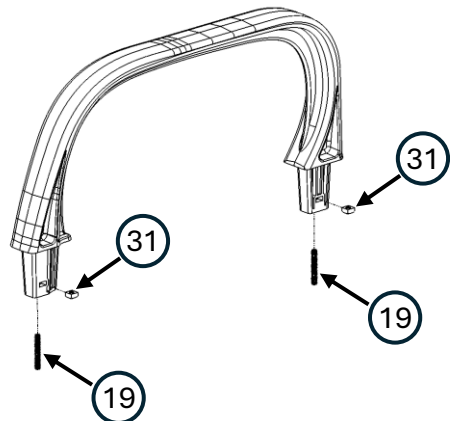

STEP (3.2)

Insert the prepped Armrests into the seat base assembly as shown and tap them down until they stop.

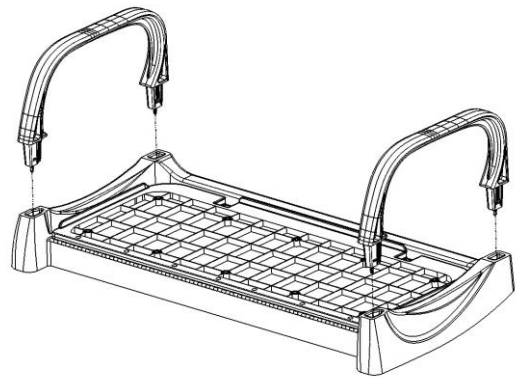

STEP (3.3)

Flip the assembly over onto a blanket or cardboard to prevent scratching the top of the armrests. Insert a **1/4" washer** and **1/4" nyloc nut** onto the end of each stud.

Fasteners located in Pack #1 of SEAT-DT5500-HW.

NOTE: Tighten nuts hand tight until armrests are fully seated.

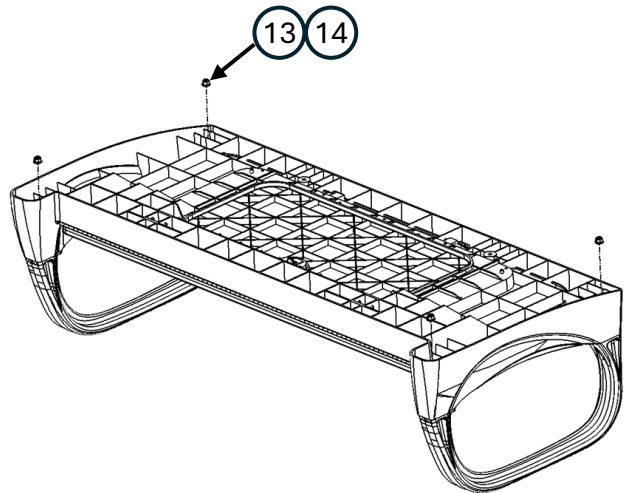

STEP (4.1) BUMPER LEG & ANGLE INSTALLATION

Attach the bumper legs to the bumper angle with **1/4" x 2" bolts**, **1/4" washers** and **1/4" nyloc nuts** through the holes as shown. Attach the bumper tabs to the bumper angle with **1/4" x 1" bolts**, **1/4" washers** and **1/4" nyloc nuts** through the holes as shown.

Fasteners located in Pack #2 of SEAT-DT5500-HW.

NOTE: DO NOT fully tighten.

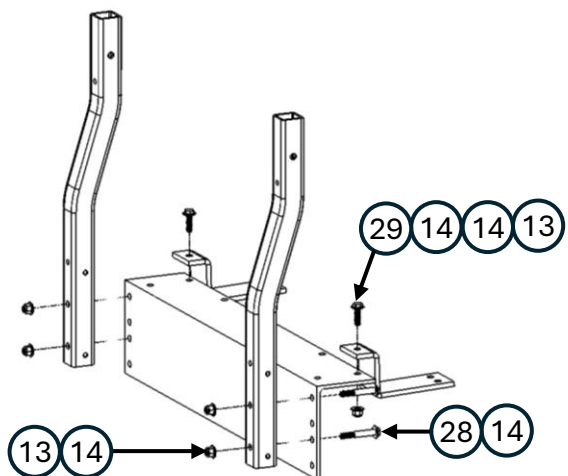

STEP (4.2)

Insert each leg into the square sockets on the bottom of the seat base as shown. Make sure the bumper angle is pointing down.

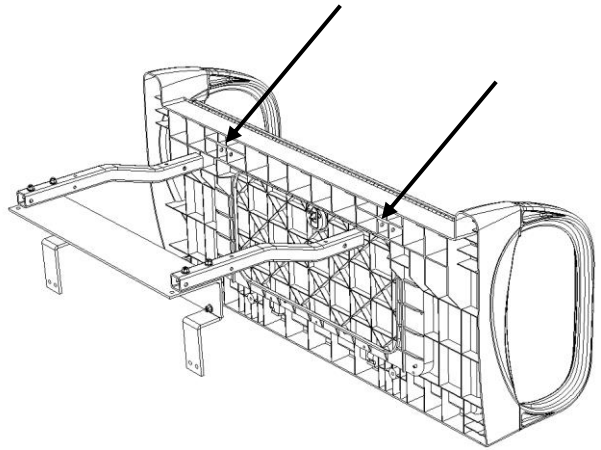

STEP (4.3)

Attach the bumper legs to the seat base with **1/4" x 2" bolts, 1/4" washers** and **1/4" nyloc nuts** through the holes as shown. Repeat on the other side.

Fasteners located in Pack #2 of SEAT-DT5500-HW.

NOTE: DO NOT fully tighten.

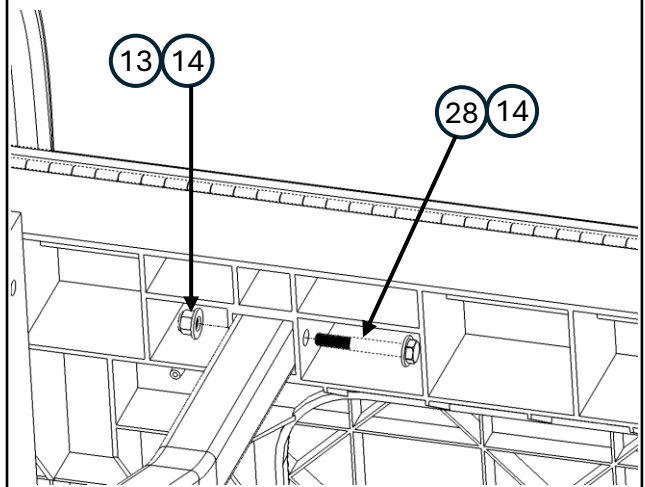

STEP (4.4) ATTACH FRONT BRACKETS

Flip the assembly back over onto a blanket or cardboard and attach the 2 front brackets to the seat base with **1/4" x 1.25" bolts, 1/4" washers** and **1/4" nyloc nuts** through the holes as shown.

Fasteners located in Pack #2 of SEAT-DT5500-HW.

Make sure to insert a **1/4" x 1.75" bolt** and **1/4" washer** through the front hole before loosely tightening.

Fasteners located in MXEX DV HW-V.
NOTE: DO NOT fully tighten.

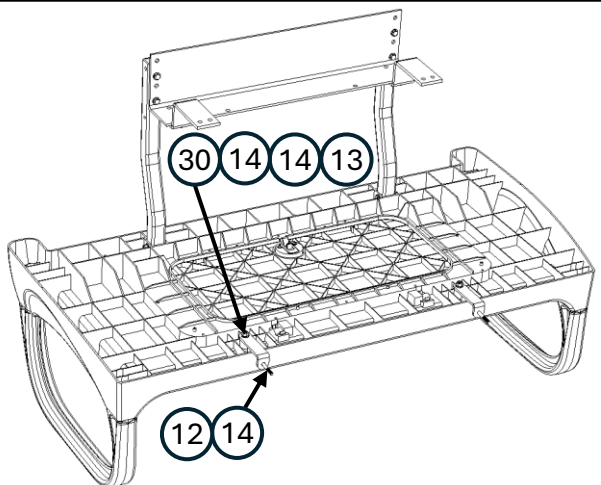

STEP (5.1) REAR SEAT MOUNTING

Position the rear seat on the back of the car with the bumper angle setting on the rear bumper. Feed the bolts in the front brackets through the holes in the seat back supports and use **1/4" washers** and **1/4" nyloc nuts** to fasten as shown.

Fasteners located in MXEX DV HW-V.

NOTE: DO NOT fully tighten.

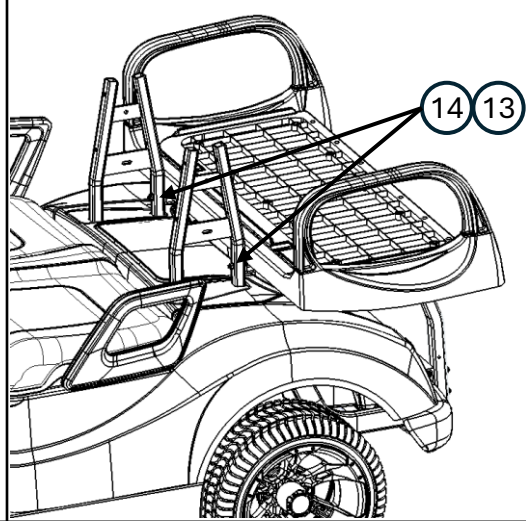

STEP (5.2)

Center bumper angle on the back of the golf car and make sure the tabs are square. Then fasten with **6mm x 30mm bolt** and **6mm washers**.

Fasteners located in MXEX DV HW-V.

NOTE: DO NOT fully tighten.

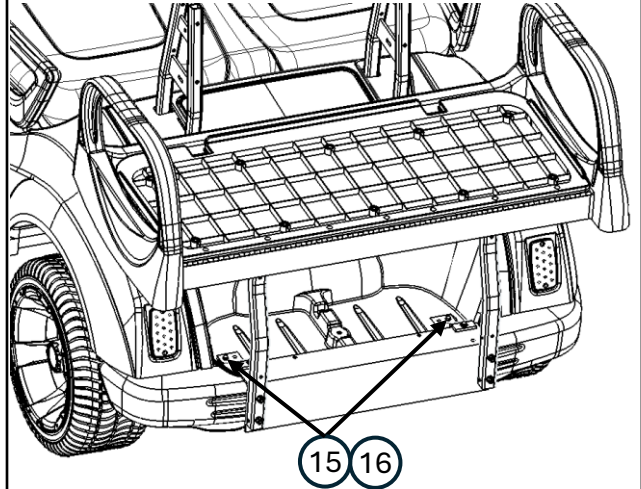

STEP (6.1) CUSHION INSTALLATION

Prepare the 2/1 seat bottom cushion by threading the **temporary stud** into the center hole indicated (*This is the thinner part of the cushion*). Then, slip the **2/1 strap** over the stud.

Fasteners located in MX5 CUSH HW-V.

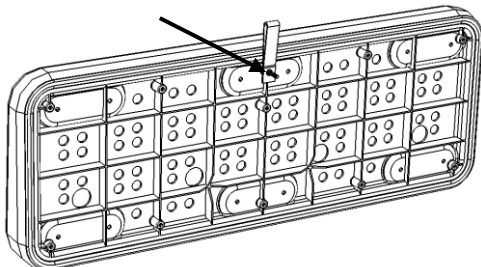

Angle the flip portion of the seat base upright 90 degrees and insert the temporary stud into the top center hole for alignment.

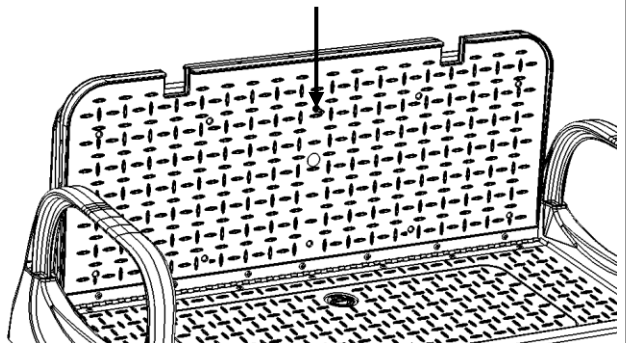

STEP (6.2)

Hand thread **1/4" x 1.5" Flat head screws** into all 4 corners first, then the remaining vacant holes. Hand tighten.
Fasteners located in MX5 CUSH HW-V.

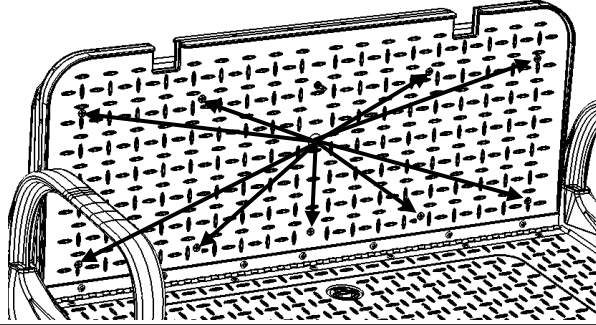

Then replace the temporary stud with a **1/4" x 1.5" Flat head screw**.
NOTE: Using a power tool to start the threads may damage or lock threads.

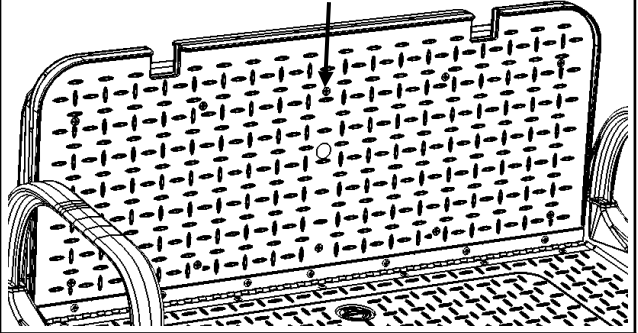

STEP (6.3)

Install the seat back cushion by following the instructions **CAT-3 Univ Seat Back Plates** supplied in the **UNIV SPL KIT**.

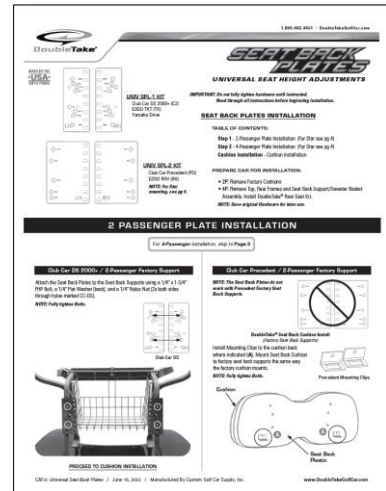

STEP (7.1) FOOTREST INSTALLATION

Flip the footrest over onto a blanket or cardboard to prevent scratching. Insert the aluminum footrest supports in the plastic slots as shown.

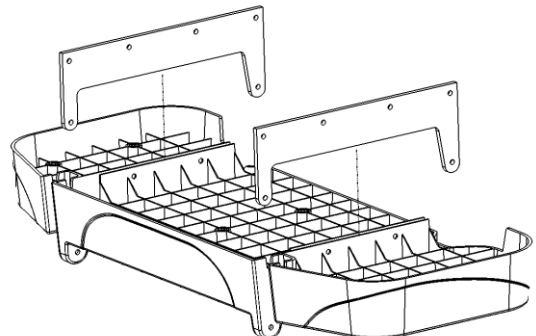

STEP (7.2)

First, insert a **D-ring Pin** through the plastic holes in the footrest and each footrest support for proper alignment. Then, insert **1/4" x 1" bolts**, **1/4" washers** and **1/4" nyloc nuts** through the two holes on each side.

Fasteners located in Pack #3 of SEAT-DT5500-HW.

NOTE: Fully hand tighten Bolts.

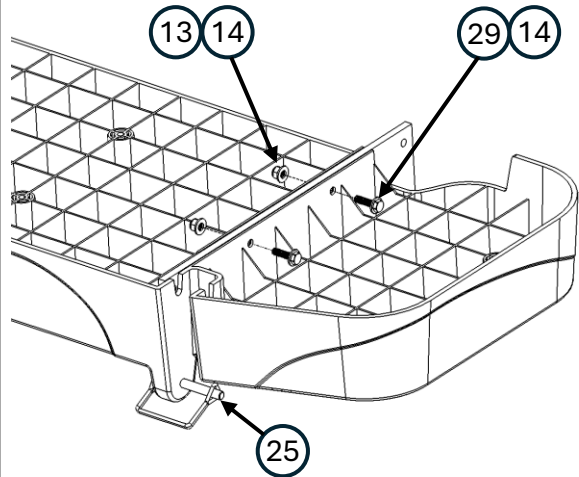

STEP (7.3)

Attach the assembled footrest to the bumper legs with **1/4" x 2.25" bolts**, **1/4" washers**, **1/4" plastic washers** and **1/4" nyloc nuts** through the holes as shown. Make sure the **1/4" plastic washers** are placed between the bumper legs and footrest supports.

Fasteners located in Pack #3 of SEAT-DT5500-HW.

NOTE: Fully hand tighten Bolts.

Some images are simplified for clarity.

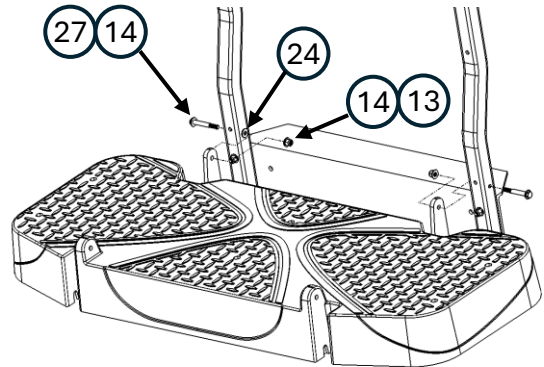

STEP (7.4)

At this time, go back and hand tighten all bolts that were previously left loose.

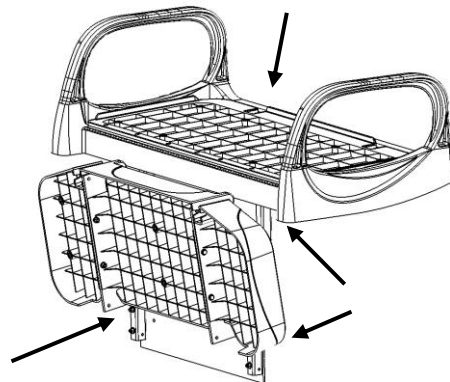

STEP (8.1) SAFETY BAR INSTALLATION

Position the safety bar tubes in footrest slots as shown and insert **D-Ring pins** through both for alignment. Then fasten the bottom of the tubes with **1/4" x 2.5" bolts, 1/4" washers** and **1/4" nyloc nuts**.

Fasteners located in Pack #4 of SEAT-DT5500-HW.

NOTE: Fully hand tighten Bolts.

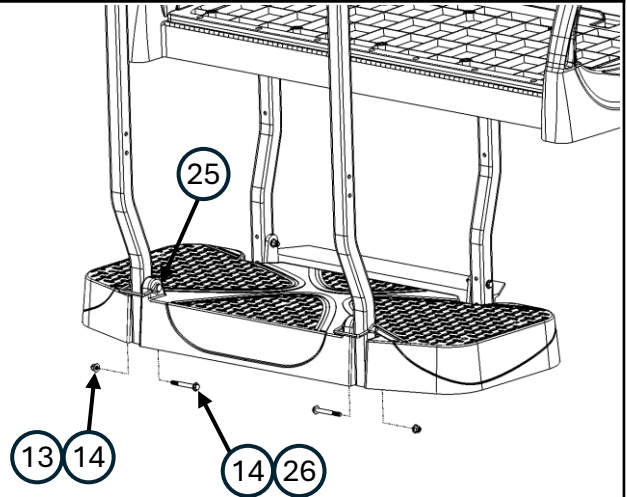

STEP (8.2)

Attach the safety bar support to the safety bar tubes with **1/4" x 2" truss head screws, 1/4" washers** and **1/4" nyloc nuts** as shown.

Fasteners located in Pack #4 of SEAT-DT5500-HW.

NOTE: Fully hand tighten screws.

Some images are simplified for clarity.

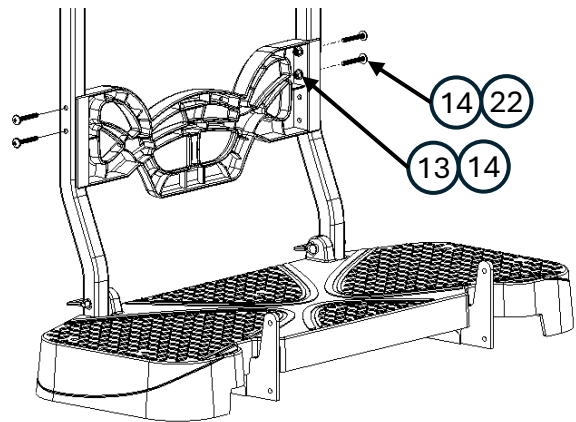

STEP (8.3)

*****If SEAT-DT5501 (Safety Bar Handle Kit) is being installed at the same time, follow accessory instruction CAT-49 before continuing.*****

Attach the safety bar top base to the safety bar tubes with **1/4" x 2" truss head screws, 1/4" washers** and **1/4" nyloc nuts** as shown. Then attach the safety bar top with **1/4" x 3" flat head screws, 1/4" washers** and **1/4" nyloc nuts** as shown.

Fasteners located in Pack #4 of SEAT-DT5500-HW.

NOTE: Fully hand tighten screws.

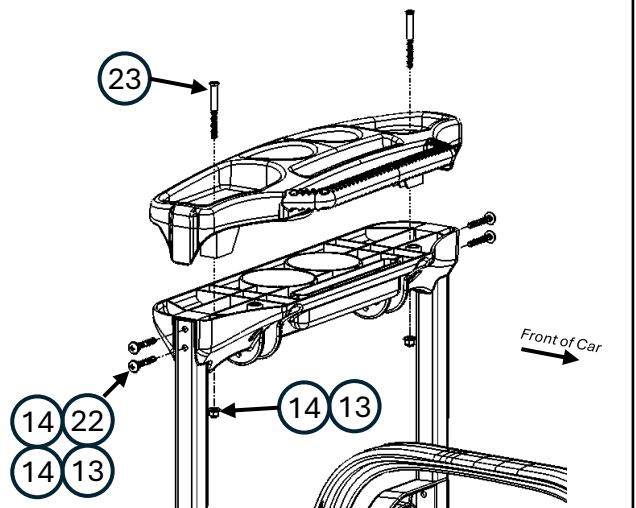

STEP (8.4)

Insert a ***D-ring Pin*** through both bottom holes of the bumper legs and footrest supports. These should remain installed for normal operation and only be removed for the loading and unloading the golf car on a truck or trailer.

Fasteners located in Pack #3 of SEAT-DT5500-HW.

**INSTALLATION IS NOW COMPLETE!
PLEASE ENJOY SAFELY!**

